



**TCM  
Series**

**BCT**  
*Bev-Carb  
Technologies*



### Features **easyCARB TCM Series**

- All metal hard fittings and plumbing lines
- Isolation valves for easy service
- Heavy-duty, low temperature final line regulator
- Fill line Safety relief valve
- Full-view, non-binding contents gauge
- Efficient venturi fill system
- Optional corrosion resistant coatings available for chlorine environments
- Highest flow rates
- Lowest NER
- Higher capacity equals fewer fills
- Separate liquid withdraw line
- Most cost efficient system for high flow
- Protective shroud

 **Taylor-Wharton**  
**CRYOGENICS**

# TCM Series

Taylor-Wharton Cryogenics

4075 Hamilton Blvd.

Theodore, AL 36582

251-443-8680

www.taylorwharton.com

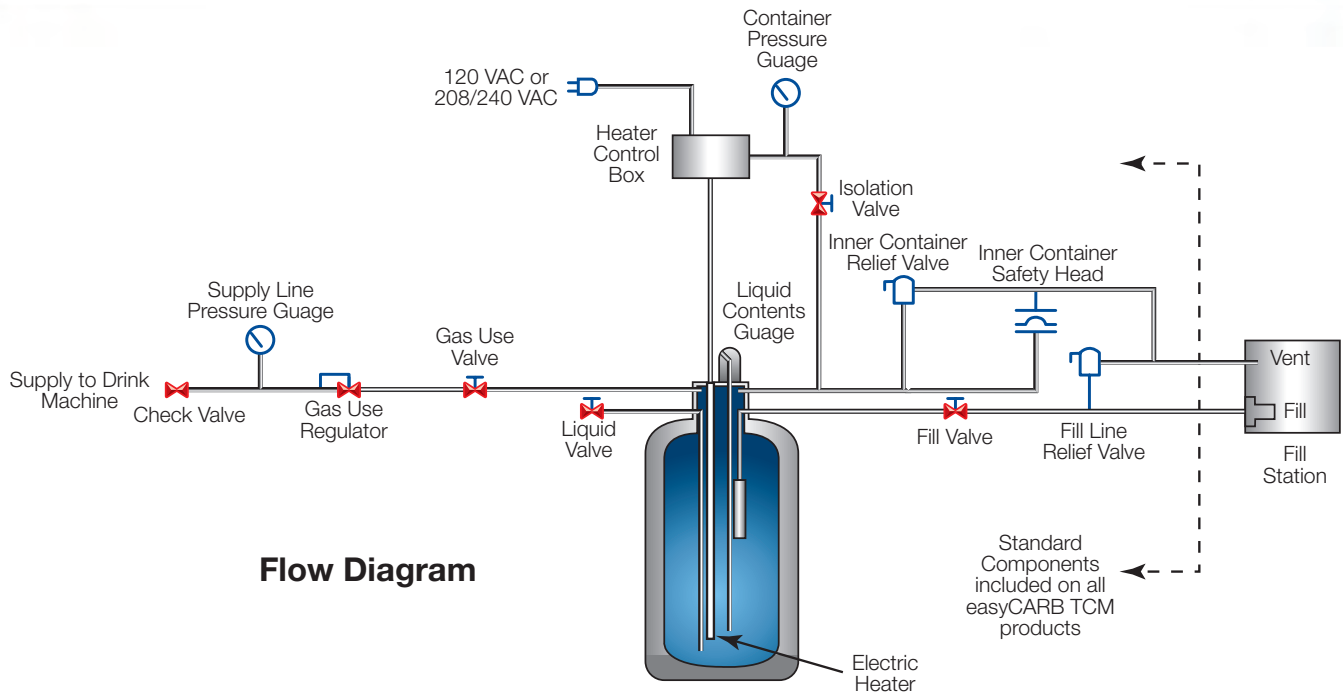

Flow Diagram

Models	TCM-600-120V	TCM-600-240V
Part Number	EC60-0C01	EC60-0C02
<b>Dimensions</b>		
Diameter	- in. 22 - mm. 559	22 559
Height***	- in. 70.4 - mm. 1788	70.4 1788
Weight (Empty)	- lb. 360 - kg. 163	360 163
<b>Capacity CO<sub>2</sub> Saturated @ 125 psig (8.6 bar)</b>		
Liquid	- lb. 594 - kg. 269	594 269
Gaseous @ NTP @ STP	cu. ft. 5195 cu. m. 136	5195 136
<b>Flow Rates</b>		
Peak Demand	- lb./hr. 30.0 - kg./hr. 13.6	60.0* 27.2*
Continuous	- lb./hr. 20.0 - kg./hr. 9.1	40.0* 18.1*
<b>Minimum Usage (No Venting)</b>		
Liquid	lb./day 2.9 kg./day 1.32	2.9 1.32
<b>Pressure Building System</b>		
Standard Operating Pressure	125 psig (8.6 bar)	125 psig (8.6 bar)
<b>Safety Device Settings</b>		
Inner Container Primary Relief Valve	300 psig (20.7 bar)	300 psig (20.7 bar)
Inner Container Safety Head	450 psig (31.0 bar)	450 psig (31.0 bar)
<b>Electrical Requirements**</b>		
Heater Voltage	120 VAC	208/240 VAC
Heater Current	7.5 amperes	6.5/7.5 amperes



\* Flow rate using 240 VAC power. Using 208 VAC power, flow rate is 40 lb./hr. (18.1 kg/hr) peak and 30 lb./hr. (13.6 kg/hr) continuous.

\*\* Only TCM models require electrical power. All electrical components UL approved. Electrical enclosure is rated NEMA 4.

\*\*\* Add 4 inches to height for legs.