



Taylor-Wharton

Harsco

Instructions

for

KeepFull Wireless/Internet Bulk Tank Liquid Level Monitoring System

PART NUMBERS 5740-8800 & 5740-8825



Do not attempt to use or maintain these units until you read and understand these instructions. Refer to Taylor-Wharton's Safety First booklet (TW-202) for handling cryogenic material. Do not permit untrained persons to maintain this equipment. If you do not understand these instructions, contact your supplier for additional information.



Taylor-Wharton

Harsco

Taylor-Wharton

4075 Hamilton Blvd.

Theodore, AL 36582

Phone: (251) 443-8680

Fax: (251) 443-2250

BT-826

Table of Contents

Table of Contents	2
Safety	3-4
Introduction	5
Installation	6
System Activation	7
Web site.....	7-10
A) Explanation of User Menus	10
B) Alarms	10
Part Numbers	10
Troubleshooting	10
Warranty Service	10
Bulk Vessel Registration Form	11
Appendix A: Example of Bulk Vessel Registration Form.....	12
Appendix B: Example of Schedule 1 - Customer Information Form.....	13

The following safety precautions are for your protection. Before performing installation, operating, or maintenance procedures read and follow all safety precautions in this section and in reference publications. Failure to observe all safety precautions can result in property damage, personal injury, or possible death. It is the responsibility of the purchasers of this equipment to adequately warn the user of the precautions and safe practices for the use of this equipment and cryogenic fluids.

SAFETY PRECAUTIONS FOR LIQUID OXYGEN

Oxygen is a colorless, odorless, and tasteless gas that can be condensed into a liquid at the low temperature of -297°F (-183°C) under normal atmospheric pressure. Approximately one-fifth of normal air is oxygen. As a liquid, oxygen is pale blue in color. Oxygen is non-flammable but vigorously accelerates the burning of combustible materials.

Keep Combustibles Away from Oxygen and Eliminate Ignition Sources

Many substances which do not normally burn in air require only a slight spark or moderate heat to set them aflame in the presence of concentrated oxygen. Other substances which are only moderately combustible in air can burn violently when a high percentage of oxygen is present.

Do not permit smoking or open flame in any area where liquid oxygen is stored, handled, or used. Keep all organic materials and other flammable substances away from possible contact with liquid oxygen. Some of the materials that can react violently with oxygen are oil, grease, kerosene, cloth, wood, paint, tar, and dirt which contains oil or grease. Under certain conditions flammable materials which have become permeated with liquid oxygen are impact sensitive and can detonate if subjected to shock.

Keep Area and Exterior Surfaces Clean to Prevent Ignition

As normal industrial soot and dirt can constitute a combustion hazard, all equipment surfaces must be kept very clean. Do not place oxygen equipment on asphalt surfaces, or allow grease or oil deposits to remain on benches or concrete surfaces in the vicinity of the oxygen equipment. Use cleaning agents which will not leave organic deposits on the cleaned surfaces. Equipment to be used in contact with liquid oxygen should be handled only with clean gloves or hands washed clean of oil.

Maintain Adequate Ventilation

Enclosed areas containing oxygen equipment should be ventilated to prevent accumulations of oxygen and thereby minimize combustion hazards.

Extreme Cold - Cover Eyes and Exposed Skin

Accidental contact of liquid oxygen or cold issuing gas with the skin or eyes may cause a freezing injury similar to frostbite. Handle the liquid so that it won't splash or spill. Protect your eyes and cover the skin where the possibility of contact with the liquid, cold pipes and cold equipment, or the cold gas exists. Safety goggles or a face shield should be worn if liquid ejection or splashing may occur or cold gas may issue forcefully from equipment. Clean, insulated gloves that can be easily removed and long sleeves are recommended for arm protection. Cuffless trousers should be worn outside boots or over the shoes to shed spilled liquid. If clothing should be splashed with liquid oxygen or otherwise saturated with the gas, air out the clothing immediately, removing it if possible. Such clothing will be highly flammable and easily ignited while the concentrated oxygen remains, and should not be considered safe for at least 30 minutes.

Replacement Parts

Must be Suitable for Oxygen Service

Many materials, especially some non-metallic gaskets and seals, constitute a combustion hazard when in oxygen service, although they may be acceptable for use with other cryogenic liquids. Make no substitutions for recommended spare parts. Also, be sure all replacement parts are thoroughly "Cleaned For Oxygen Service" in accordance with Compressed Gas Association (CGA) Pamphlet G-4.1 "Cleaning for Oxygen Service" or equivalent industrial cleaning specifications.

Observe Safety Codes When Locating Oxygen Equipment

Before locating oxygen equipment, become thoroughly familiar with National Fire Protection Association (NFPA) Standard No. 50, "Bulk Oxygen Systems", and with all federal, state and local safety codes. The NFPA Standard covers the general principles recommended for the installation of bulk oxygen systems on industrial and institutional consumer premises.

CAUTION: When installing field fabricated piping, make certain a suitable safety valve is installed in each section of piping between shut-off valves.

For more detailed information concerning safety precautions and safe practices to be observed when handling cryogenic liquids consult CGA pamphlet P-12 "Handling Cryogenic Liquids" available from the Compressed Gas Association, 1235 Jefferson Davis Highway, Arlington, Va. 22202.

SAFETY PRECAUTIONS FOR LIQUID NITROGEN

Nitrogen is an inert, colorless, odorless, and tasteless gas which makes up four-fifths of the air you breathe. Liquid nitrogen is obtained by cooling air until it becomes a liquid and then removing the oxygen which makes up the other fifth of the air. Liquid nitrogen is at a temperature of -320°F (-196°C) under normal atmospheric pressure.

Extreme Cold - Cover Eyes and Exposed Skin

Accidental contact of liquid nitrogen or cold issuing gas with the skin or eyes may cause a freezing injury similar to frostbite. Handle the liquid so that it won't splash or spill. Protect your eyes and cover the skin where the possibility of contact with the liquid, cold pipes and cold equipment, or the cold gas exists. Safety goggles or a face shield should be worn if liquid ejection or splashing may occur or cold gas may issue forcefully from equipment. Clean insulated gloves that can be easily removed and long sleeves are recommended for arm protection. Cuffless trousers should be worn outside boots or over the shoes to shed spilled liquid.

Keep Equipment Area Well Ventilated

Although nitrogen is non-toxic and non-flammable, it can cause asphyxiation in a confined area without adequate ventilation. Any atmosphere which does not contain enough oxygen for breathing can cause dizziness, unconsciousness, or even death. Nitrogen being colorless, odorless, and tasteless cannot be detected by the human senses and will be inhaled normally as if it were air. Without adequate ventilation, the expanding nitrogen will displace the normal air without warning that a non-life-supporting atmosphere is present. Store liquid containers outdoors or in other well ventilated areas.

Dispose of Waste Liquid Nitrogen Safely

Dispose of waste liquid nitrogen out-of-doors where its cold temperature cannot damage floors or driveways and where it will evaporate rapidly. An outdoor pit filled with clean sand or gravel will evaporate liquid nitrogen safely and quickly.

CAUTION: When installing field fabricated piping, make certain a suitable safety valve is installed in each section of piping between shut-off valves.

For more detailed information concerning safety precautions and safe practices to be observed when handling cryogenic liquids consult CGA pamphlet P-12 "Handling Cryogenic Liquids" available from the Compressed Gas Association, 1235 Jefferson Davis Highway, Arlington, VA 22202.

NOTE: Argon is an inert gas whose physical properties are very similar to those of nitrogen. For handling of liquid argon, follow the safe practices described for the handling and use of liquid nitrogen.

Introduction

The bulk tank liquid level monitoring system provided by Taylor Wharton provides the latest technology for local as well as remote observation of a bulk tank's contents. This system enables an operator to check tank liquid level from any computer that has Internet access as well as at the tank site. With its local digital display it is a direct replacement for the analog differential pressure "Contents Gauge" commonly being used. Because wireless transmission is used and the unit is battery powered, no external wiring is required. Therefore installation is as easy as the replacement of the "Contents Gauge."

The system consists of a differential pressure transmitter, a local digital display, a cellular transmitter/receiver, and a database service that is accessed through an Internet Web site. Solar assisted batteries supply power for long life. The differential pressure transmitter connects to the same tank instrument lines as the "Contents Gauge." This component comes with 0-325" and 0-600" water column spans. Every hour the pressure transmitter

senses the tank liquid level by measuring the differential pressure produced by liquid in the tank. Transmitter output is communicated to the tank mounted telemetry device in the form of a 4 to 20 mA electrical signal. The hourly readings are locally stored and at least one time per day they are all transmitted to the database. For local observation of the current liquid level, a button is depressed causing a tank reading to be taken. The tank will be sampled every 10 seconds for 15 minutes. During a fill the same button is used and the tank will be sampled at the same rate for 1 hour.

Figure 1 below shows the general layout of the telemetry device.

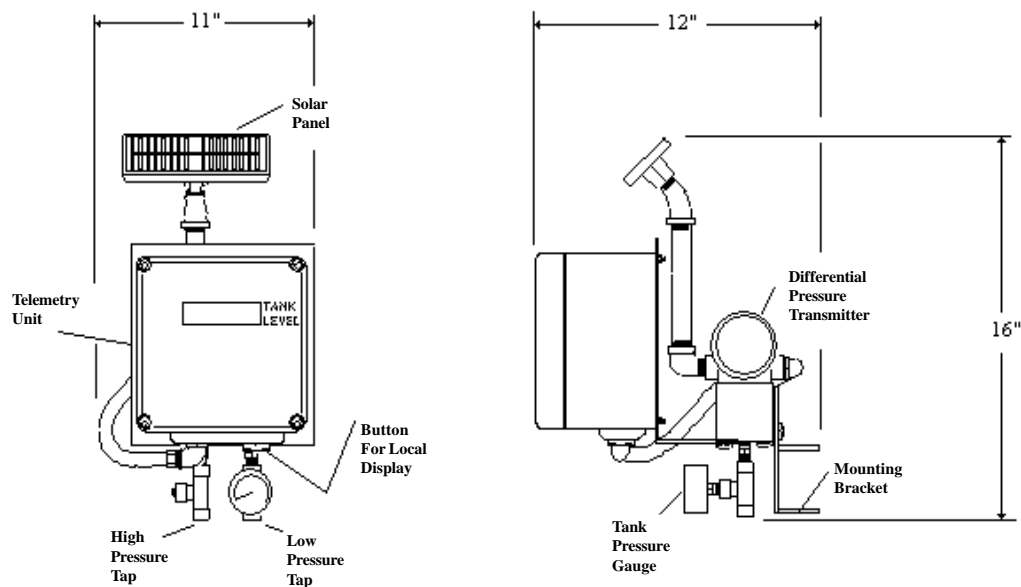

Figure 1: General Layout and dimensions

Installation

Before installing the telemetry unit inspect it carefully. Report any damage to the carrier and Taylor Wharton Customer Service. As shipped, the unit is operational and ready to be installed on the tank. For installation on a typical tank with an existing Contents Gauge follow these steps.

- 1) Fill out the Bulk Vessel Registration Form supplied with this manual and fax it to Taylor Wharton Customer Service. This form, along with the Customer Information Form, filled out at the time of purchase is used to prepare your Internet Web Site.
- 2) Verify that the differential pressure transmitter span (inches of water) covers the range required for the tank.
- 3) Record the present liquid level and tank pressure as indicated on the existing Contents Gauge Assembly. Also, label the high and low-pressure instrument lines.
- 4) Close both instrument valves to isolate the existing Contents Gauge Assembly from the tank. Open the Instrument Bypass valve to equalize the pressure between the high-pressure and low-pressure side of the Contents Gauge Assembly.
- 5) Carefully loosen the connections at the Contents Gauge Assembly to relieve any pressure and then remove the assembly.
- 6) Identify the high (H) and low-pressure (L) sides of the Differential Pressure Transmitter on the Telemetry Unit.
- 7) Mount the Telemetry Unit on the tank using the supplied bolts. See figure 2. The Telemetry Unit bracket is designed to mate to a typical bracket supplied with the tank. If there is a mismatch some field adaptation may be required.

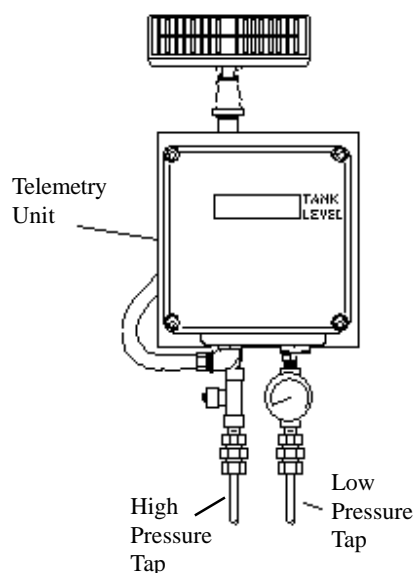

Figure 2: Typical Installation

- 8) Solar panel must be directed to maximize southern sun exposure. Turn the solar panel by rotating the 45° elbow as much as one-quarter turn to direct the panel to a maximized southern sun exposure. **Caution, only apply torque to 45° elbow using appropriate wrenches.**
- 9) Install an appropriate pressure gauge in the tee at the low-pressure side of the telemetry unit. See figure 2.
- 10) Connect the instrument lines and then open the instrument valves.
- 11) Leak test all connections using a suitable liquid leak detector.
- 12) To obtain the current reading momentarily hold the "Fill Button" until you see "FILL" on the display. The screen will blink with the current reading. If "ERROR" is displayed the high and low-pressure connections are most likely reversed.
- 13) Activate your website.

Figure 2: Typical Installation

Notes: *All supplied pressure parts are suitable and have been cleaned for oxygen service. All field installed parts must have a pressure rating equal to or higher than the tank MAWP, be suitable for oxygen service and likewise cleaned. See the safety precautions in the front of this manual.*

Seal all pipe threads using Teflon tape.

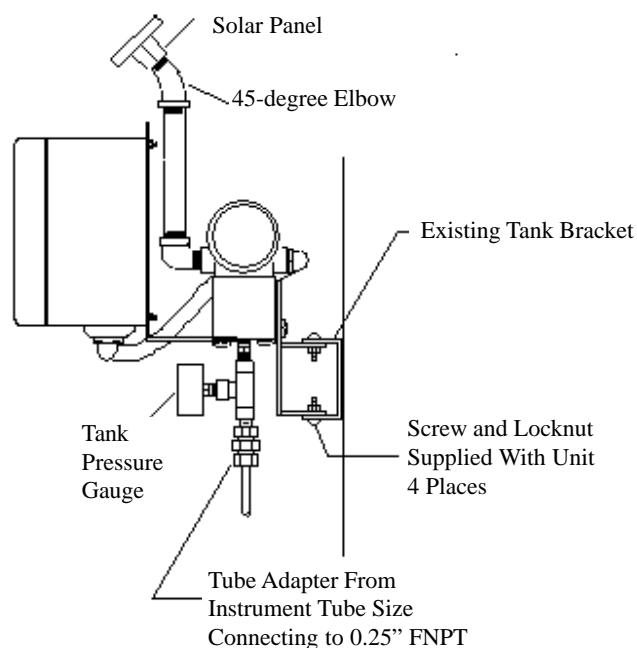

System Activation

Your Internet service provider is DataQwest Inc. Please call their technical service group at (908) 464-2646 ext. 12 to commission your telemetry system. Units may be commissioned Monday through Friday from 7:30 AM to 5:00 PM EST.

You will be instructed to hold the "Fill Button" depressed for about 20 seconds. "LOG ON" and then "CALL" should appear on the display. The unit will log on to the network. Expect this to take about 5 minutes. If "ERROR" is displayed a failure to connect with the network is indicated.

In this event, please call DataQwest. Upon successful transmission the Telemetry unit will receive its alarm points and begin to log data. It is now on-line and ready to report liquid level information.

Web site

After the telemetry unit is activated wait at least 3 business days for the unit to collect and transmit the first readings before accessing the DataQwest Web site for your tank. You may access your telemetry Web site at <http://www.dataqwestinc.com>. The following screen should appear.



Click on "DATA ONLINE" at the left of the screen. A log on box like shown below will appear.



Type your DataQwest assigned user name and password and click "OK". You should have received this information via telephone or letter from DATAQWEST. If you have not received your user name and password, contact DATAQWEST's Technical Service Group at (908) 464-2646 ext. 12. A screen that shows a list of states where your telemetry equipped tanks are located will appear.

Site Directory, State Listing

- [California](#)
- Delaware
- Georgia
- New Jersey
- New York
- Rhode Island
- Texas
- Virginia

The first view in this sample demonstration presents the listing of states where your monitored tanks are located

Click on the state to access a screen that will direct you to cities.

California, Cities

- [Anaheim](#)
- Los Angeles
- San Francisco
- San Juanita
- San Jose
- Tyrolia

Highlighting "California" brings up a second screen listing your monitored tanks in that state, by city

Clicking on the city of interest will produce a screen listing individual sites.

Anaheim, California: Sites

- West Coast Chemicals
- California Paint Co.
- USA Soap Inc.
- Acme Chemicals
- Petro Products Inc.
- ABC Products Tank Farm

Clicking on a city brings up the listing of your tanks by customer location

Click on the site for a listing of tanks.

Site Summary
ABC Company - Tank Farm, Anaheim, CA

Description	Date/Time	State	Reading
Tank #1, Oxygen	01/09/97 12:00	Normal	50% full 4,856 pounds
Tank #2, Nitrogen	01/09/97 12:00	Re-Order	25% full 7,652 pounds
Tank #3, Co2	01/09/97 12:00	Critical	10% full 3,450 pounds

Highlighting a specific tank farm presents the summary of all tanks monitored at this facility. The tank icons represent graphically the current inventory. This screen identifies tanks, the product in them, the time data was last retrieved, the order/reorder status and the specific inventory level

DATA ONLINE™ Site Home Last Next Site Structure

Clicking on the tank of interest will allow you to see its data.

Configuration for Tank #1, Oxygen
ABC Products - Tank Farm, Anaheim, CA

Site Contact: Jerry Squires Tel: 908 464 2646
E-Mail Address: JSquires@ABCComponents.com

Description: Tank #1
Level Units: Inches
Sensor Range: 0 to 132 inches
Normal Range: 34.2 to 94.1 inches
Critical Points: 29.2 and 99.1 inches
Logging Rate: 60 minutes

Tank Details:

Volumetric Units: Gallons
Product: Oxygen
Style: Vertical (2:1)
Diameter: 50.0 inches
Length: 120 inches

DATA ONLINE™
Change Request Configuration Events Historical Data Site Summary Site Directory

Explanation of User Menus

At the bottom of this screen there are six choices for viewing tank information and making changes to system parameters. Click on each to view its features and functions.

Change Request: This screen allows changes to tank and sensor parameters. Upon receipt of a change request “DataQwest” technicians will change the parameters.

Configuration: As shown above this screen gives general tank and sensor information.

Events: Product deliveries and other important events are displayed, with information about the time of their occurrence and the tank level afterwards.

Historical Data: Historical data showing product usage and replenishment is display along with fill levels and alarm points.

Site Summary: As shown above this screen lists the tanks that are located at a particular site.

Site Directory: As shown above this screen lists the States where tank sites are located.

Alarms

When product level falls below a “critical point” the telemetry unit will within the hour transmit an alarm to the Web site. A predetermined contact in your organization will immediately be notified by E-mail or Fax.

Part Numbers

Two different telemetry units cover a differential pressure range from 0 to 600 inches of water. Order Taylor Wharton’s part number 5740-8800 to receive a unit that spans the range from 0 to 325 inches of water. For 0 to 600 inches of water order part number 5740-8825.

Trouble Shooting

If erratic or erroneous readings are indicated check all pressure connections for leakage. Repair any leaks. If the unit still is displaying false readings or no leaks are found, call Taylor Wharton Customer Service.

Warranty and Service

For warranty and service call Taylor Wharton Customer Service: 1-800-TW-TANKS.

Bulk Vessel Registration Form

Please fax this completed form Attention: Taylor Wharton Technical Response Group (334) 443-2250 for each telemetry device to be installed. This information should agree with that provided on "Schedule One: Customer Information form" that was provided when your telemetry unit was ordered.

Contact for Website User Name and Password

Customer Name: _____ Contact: _____ Date: _____
Street: _____ City: _____ State: _____ Zip: _____
Phone: _____ Service Agreement Number: _____

Tank Site Information

Site Name: _____ Installed by: _____
Street: _____ City: _____ State: _____ ZIP: _____
Phone: _____

Please sketch the overall tank area, noting South and solar panel direction.

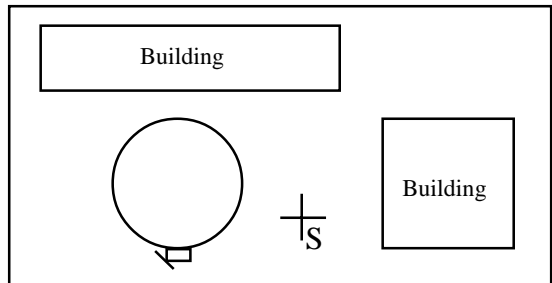

Note any power sources: _____

Note any obstructions: _____

Tank Information

Tank identification at tank site: (Serial # preferred) _____ (Nominal size/model) _____

Product: _____ Full Reading: _____ (inches of H₂O)

Reorder Reading: _____ (inches of H₂O) Low Level Alarm Reading _____ (inches of H₂O)

Please circle one:

Tank Orientation: Vertical or Horizontal

Unit installed on: Tank or Instrument Stand

Original D.P. Gauge: Removed or Retained

Are Extra Alarms to Customer Required? Yes or No

Tank liquid level and pressure prior to disconnection of existing gauges:

Pressure: _____ (psig)

Liquid level _____ (inches)

Telemetry Device Information

Device I.D. _____ Sensor span: _____

Comments:

Appendix A: Example of Bulk Vessel Registration Form

Bulk Vessel Registration Form

Please fax this completed form Attention: Taylor Wharton Technical Response Group (334) 443-2250 for each telemetry device to be installed. This information should agree with that provided on "Schedule One: Customer Information form" that was provided when your telemetry unit was ordered.

Contact for Website User Name and Password

Customer Name: JL Welding Company Contact: Jane Doe Date: 00/00/00
Street: 123 Any Street City: Someville State: XX Zip: 00000
Phone: (000) 000-0000 Service Agreement Number: TWRB-123

Tank Site Information

Site Name: Ace Metal Works Inc. Installed by: Jack Doe
Street: 78 Ginger Rd. City: Someville State: XX Zip: 00000
Phone: (000) 000-0000

Please sketch the overall tank area, noting South and solar panel direction.

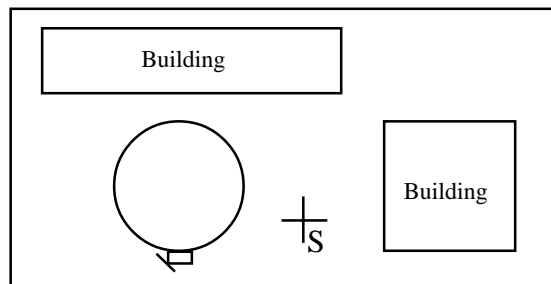

Note any power sources: _____

Note any obstructions: _____

Tank Information

Tank identification at tank site: (Serial # preferred) S/N-XXXX (Nominal size/model) VT-6,000-250
Product: Nitrogen Full Reading: 311 (inches of H₂O)
Reorder Reading: 100 (inches of H₂O) Low Level Alarm Reading 85 (inches of H₂O)

Please circle one:

Tank Orientation: Vertical or Horizontal

Unit installed on: Tank or Instrument Stand

Original D.P. Gauge: Removed or Retained

Are Extra Alarms to Customer Required? Yes or No

108
152

Telemetry Device Information

Device I.D. FGD123P4 Sensor span: 0-400
Comments _____

Appendix B: Example of Schedule 1- Customer Information Form

Schedule 1: Customer Information Form

Customer Billing & Notice Information for Monthly Web Service

Customer Name: ABC Gas Distributor Contact: John Williams
Street: 123 West Street City: Someville State: XX Zip: 00000 Phone: (000) 000-0000
Service Agreement Number: TWRB-123 Effective Date: 00/00/00

Fees

Monthly Fee: \$ _____ 1x Activation Fee: \$ _____

Tank Site Information

Site Name: ACE Metal Works Inc. Contact (if any): Jack Doe
Street: 7878 Ginger Road City: Someville State: XX Zip: 00000 Phone: (000) 000-0000
Transmission Coverage Checked: Y or N Transmission Frequency: Every 12/24/____ hrs.

Tank Information

Tank Identification at Tank Site (Serial Number if possible): S/N-XXXX
Nominal Size & Model: VT-6,000-250 Product: Nitrogen
Full Reading: 311 (inches of H2O)
Reorder Reading: 100 (inches of H2O)
Low Level Alarm Reading: 85 (inches of H2O)

Please Circle One:

Tank Orientation: Vertical or Horizontal Unit installed on: Tank or Instrument Stand
Are Extra Alarms to Customer Required: Y or N Original D.P. Gauge: Removed or Retained

Contact for Web Site User name and Password

Customer Name: JL Welding Company Contact: Jane Doe
Street: 77 Hickory Lane City: Someville State: XX Zip: 00000 Phone: (000) 000-0000
Current DataQwest Web Site Username (if any): JLWelding
Alarm Method: Email Address: JLWelding@JLWelding.com
Fax Number: (000) 000-0000
Name of Contact: Jack Smith



Taylor-Wharton

Harsco

Taylor-Wharton

4075 Hamilton Blvd.

Theodore, AL 36582

Phone: (334) 443-8680

Fax: (334) 443-2250

www.taylorwharton.com